

NEUTRAL GROUNDING RESISTORS



CATALOG
2019

Our Trademarks



Where we are?

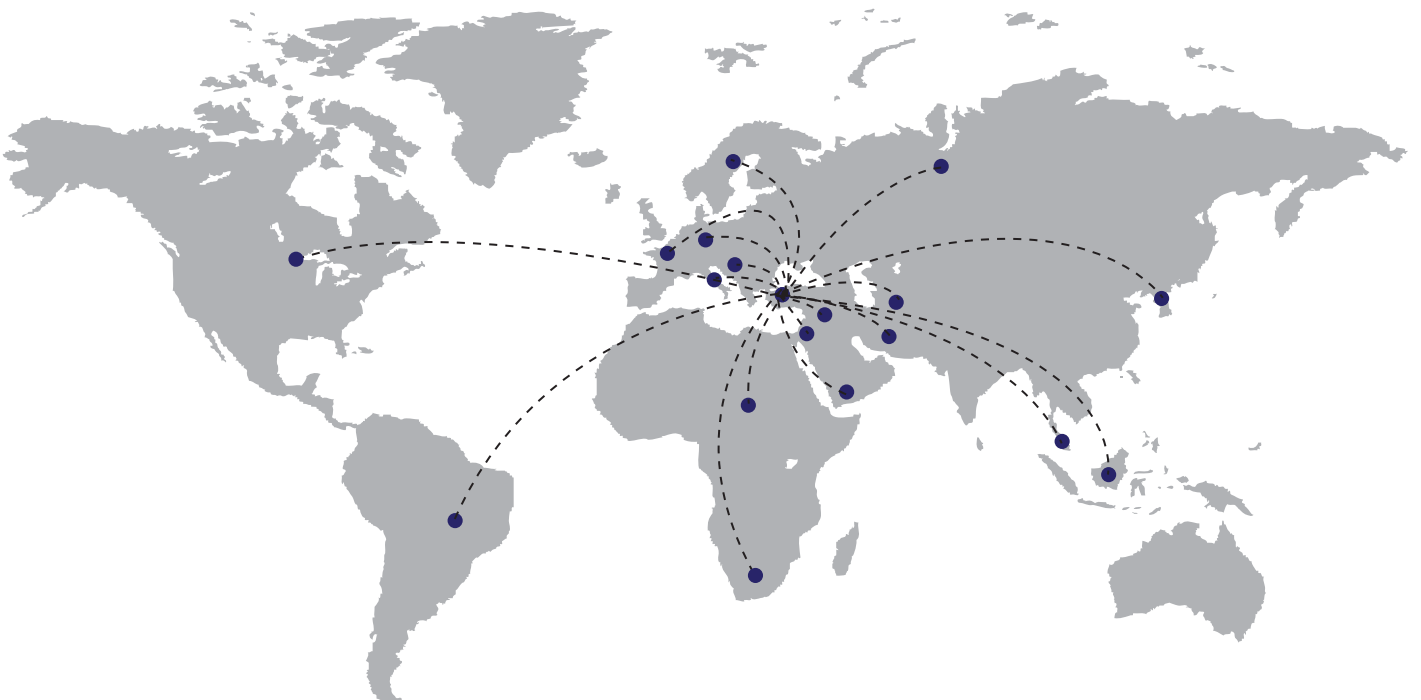

Neutral Grounding Resistors

Neutral Grounding Resistors.....	4
Ungrounded System (No Intentional Grounding).....	5
Neutral Grounded System Through a Resistance	6
Low-Resistance Grounding	6
High-Resistance Grounding	7
Neutral Grounded System Through a Peterson Coil (Resonant Grounding)	8
Solidly Grounded System	9
Grounding System Through a Transformer	10
Neutral Grounded System Through a Single-Phase Transformer and a Resistor	10
Obtain the System Neutral with Zig-zag Transformer	10
Obtain the System Neutral with Wye-Delta Transformer	11
Obtain the System Neutral with Wye-Open Delta Transformer	11
Other Neutral Earthing Resistance Applications.....	12
Generator Neutral Cubicle & Generator Leads Cubicle	13
High-Resistance Neutral Grounding System	13
Neutral Resistor Monitoring System	14
Characteristic of Grounding Methods (Comparison summary)	16

Neutral Grounding Resistors



Our resistors are manufactured against harsh weather and industrial conditions with the range from Low Voltage to High Voltage at 52 kV insulation level and from low currents up to high currents of 10 kA.

The most common requirements are manufactured with the line of standard products and the others are designed and developed as tailor made according to the project characteristics.

Technical Characteristics

- Nominal Voltage up to 52 kV insulation class
- Fault Current up to 10 kA
- Fault Duration

Other Parameters

- Continuous current rating; important for the resistor performance especially at high IP degrees
- Protection degree of enclosure; standard IP23, available from IP00 (w/o enclosure) to IP55,
- Enclosure; hot dip galvanized is standard, AISI304 / AISI316 stainless steel and RAL 7035 color are options
- Auxiliary components; like Switches, Disconnectors, Current Transformers, etc.



How to ground an electrical system is an important decision for the electricity generation and distribution system.

The purpose of system grounding is;

- to control the system's voltage with the respect to ground, within predictable limits,
- to provide for a flow of current that will allow detection of a short-circuit between phases and ground and disable the voltage source (such as transformer or generator).

The Basic Methods of Neutral Grounding are as follows and each has its own purpose, advantage and disadvantage;

1. Through a Resistance
 - Low-resistance
 - High-resistance
2. Through a Reactance
3. Through a Peterson Coil (Resonant Grounding)
4. Through a Solidly grounded system
5. Through a Transformer
 - Consist of a Single-Phase Transformer and Resistor,
 - Ziz-Zag Transformer,
 - Wye-Delta Transformer,
 - Wye-Open Delta Transformer



Ungrounded System (No Intentional Grounding)

In an ungrounded system, there is no intentional connection between the system conductors and ground. However, there always exists a capacitive coupling between one system conductor and another, and also between system conductors and ground. Consequently, the so-called ungrounded system is a capacitance grounded system, by virtue of the distributed capacitance from the system conductors to ground. Since the capacitance between phases has little effect on the grounding characteristics of the system, it will be disregarded.

Initially, the distributed capacitive reactance to ground, X_{co} , is assumed to be balanced and in an unfaulted condition, with balanced three-phase voltages applied to the lines, the capacitive charging current, I_{co} , in phase will be equal and displaced 120° from one another. The phase voltages to ground will also be equal and displaced 120° from one another.

If one of the system conductors, phase C for example, faults to ground, current flow through that capacitance to ground will cease, since no potential difference across it now exists. The voltage across the remaining two distributed capacitors to ground will, however, increase from line to neutral to line to line. The capacitive charging current, I_{co} , in the two unfaulted phases will therefore increase by the square root of 3 and the line-to-ground voltages are no longer 120° , but 60° apart.

In an ungrounded system, it is possible for destructive transient overvoltages to occur throughout the system during restriking ground faults. These overvoltages, which can be several times normal in magnitude, result from a resonant condition being established between the inductive reactance of the system and the distributed capacitance to ground.

These overvoltages may cause failure of insulation at multiple locations in the system. Transient overvoltages from restriking ground faults are the main reason why ungrounded systems are no longer recommended and grounded systems of some form are the predominant choice.

At the same time, the location of the fault in this system is difficult to detect and takes time. Therefore, the continuity of the system can not be ensured.

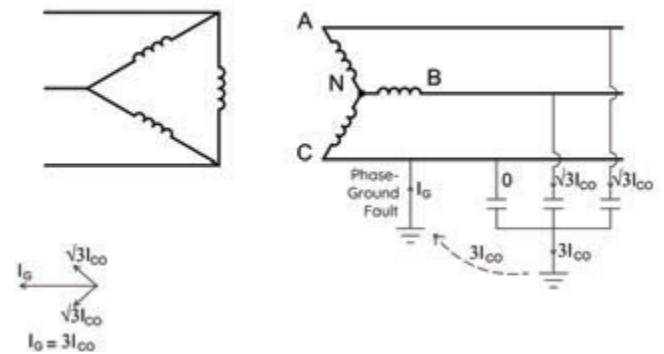
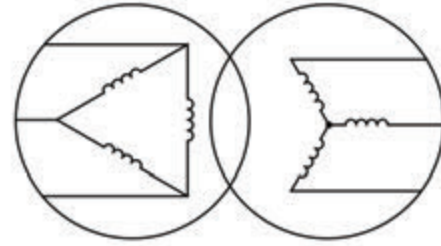

Neutral Grounded System Through a Resistance

In a resistance-grounded system, the neutral of the transformer or generator is connected to ground through a resistor. Due to the resistance has a considerably higher ohmic magnitude than the system reactance at the resistor location, the line-to-ground fault current is primarily limited by the resistor itself.

The reasons for limiting the current by resistance grounding include the following;

- To reduce mechanical stresses in circuits and apparatus (such as transformers, motors, cables etc.) carrying fault currents.
- To reduce electric-shock hazards to personnel caused by stray ground-fault currents in the ground-return path.

Low-Resistance Grounding

Low-resistance grounding is designed to limit ground-fault current to a range between 100 A and 1000 A. The neutral resistor, R , is calculated according to $R = V_{LN}/I_g$, where V_{LN} is the system line to neutral voltage and I_g is the desired ground-fault current that can be determined according to the values determined by the electricity management in the country where the system is installed or the short circuit current of the transformer or generator can not be damaged by the windings.

Low-resistance grounding has the advantage of facilitating the immediate and selective clearing of a grounded circuit. This requires that the minimum ground-fault current be large enough to positively actuate the applied ground-fault relay. One method of detecting the presence of a ground fault uses an overcurrent relay, 51G. When a ground fault occurs, the neutral potential is raised to approximately line-to-neutral voltage, resulting in current flow through the resistor. A typical turns ratio for the current transformer is indicated. Upon indication that a ground fault has occurred, action would be initiated to disconnect the transformer from the secondary circuit.

Normal practice is to rate it for 5 s or 10 s, depending upon the degree of security appropriate for the application and the selectivity provided by the relays in the secondary circuit. Low-resistance grounding finds application in medium-voltage systems up to 36 kV. By limiting ground-fault currents to hundreds of amperes, instead of thousands of amperes, damage to expensive equipment is reduced. At the same time, low-resistance grounding are limit transient overvoltages to safer limits. A surge arrester is parallel connected to the neutral resistance may also be used, which is selected for the voltage protection.

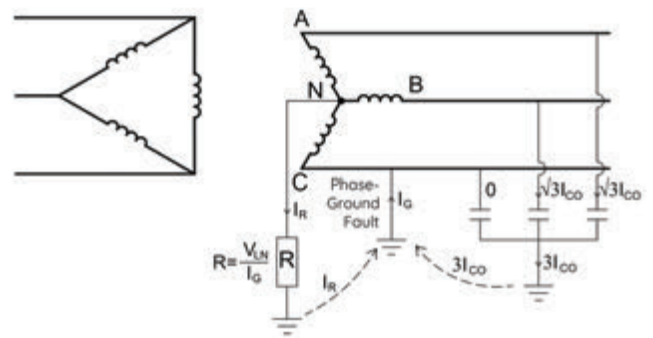
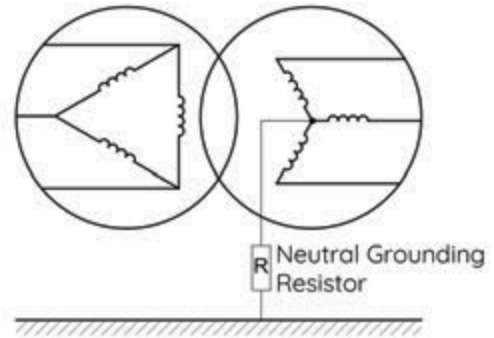

Neutral Grounded System Through a Resistance

High-Resistance Grounding

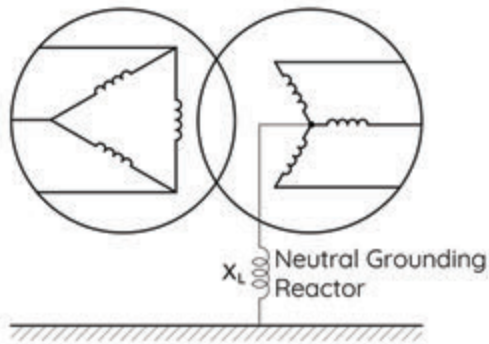

High-resistance grounding employs a neutral resistor of high ohmic value. The value of the resistor is selected to limit the current, I_r , to a magnitude equal to or slightly greater than the total capacitance charging current, $3 I_{CO}$.

Typically, the ground-fault current, I_g , is limited to 10 A or less. Generally, the ground fault current is limited to 10 A up to 15 kV generators. For example, If the ground fault current is to be limited to 10 A for 11 kV generator, $(11 \sqrt{3} \text{ kV}) / 10 \text{ A} = 635 \text{ ohm}$ resistor shall be used.

High-resistance grounding usually does not require immediate clearing of a ground fault since the fault current is limited to a very low level. The protective scheme associated with high-resistance grounding is usually detection and alarm rather than immediate trip out.

A typical application for detecting a ground fault in a high-resistance grounded system is to be used the resistance with grounding transformer that is connected to the neutral point. Under normal operation, the neutral point of the transformer is at zero potential. When a single line-to-ground fault occurs, the neutral point is raised to approximately line-to-neutral voltage. This rise in voltage is then detected using an overvoltage relay, 59. A step-down transformer is typically used to reduce the line to neutral voltage of the system to a level (usually 120 V and 230 V) acceptable to the relay.

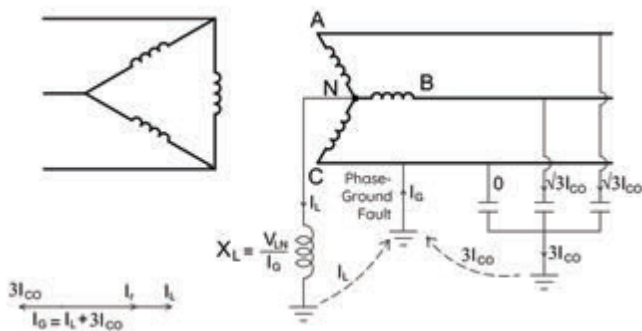

High-resistance grounding has the following advantages:

- Service continuity is maintained. The first ground fault does not require process equipment to be shut down.
- Transient overvoltage due to restriking ground faults is reduced.
- A signal tracing or pulse system will facilitate locating a ground fault.
- It eliminates flash hazards to personnel associated with high ground-fault currents.
- The need for and expense of coordinated ground-fault relaying is eliminated.

High-resistance grounding is generally employed up to 6,3 kV systems where service continuity is desired and capacitive charging current is not excessive and industrial locations where there are no line-to-neutral loads.

In this application, the neutral point is connected to the ground through a reactance (coil). The ground fault that may flow in a reactance-grounded system is a function of the neutral reactance.

In a reactance-grounded system, the available ground-fault current should be at least 25% and preferably 60% of the three-phase fault current to prevent serious transient overvoltages. This is considerably higher than the level of fault current desirable in a resistance grounded system, and therefore reactance grounding is usually not considered an alternative to low-resistance grounding.

Neutral Grounded System Through a Peterson Coil

Reactance grounding is typically reserved for applications where there is a desire to limit the ground-fault duty to a magnitude that is relatively close to the magnitude of a three-phase fault. Use of neutral grounding reactors to provide this fault limitation will often be found to be a less expensive application than use of grounding resistors if the desired current magnitude is several thousand amperes.

These circumstances may arise in one of two possible instances. One potential setting is where a large substation feeds a medium-voltage distribution system, and the total zero-sequence impedance of the step-down transformers in the station causes the single line-to-ground-fault current to greatly exceed the magnitude of a three-phase fault, and ground-fault limitation is desired to keep the total fault current within the reasonable limits. These conditions tend to occur most often in electric utility distribution practice.

Grounding through the Peterson coil is also called ground fault neutralizer or compensation. A ground-fault neutralizer is a reactor connected between the neutral of a system and ground. The reactor, X_L , is specially selected, or tuned, to resonate with the distributed capacitance, X_{CO} of the system so that a resulting ground-fault current is resistive and low in magnitude. A resistance, r , is shown depicting reactor losses. The resulting ground-fault current is in phase with the line to neutral voltage so that current zero and voltage zero occur simultaneously.

This type of grounding system is rarely seen in some electricity distribution networks in the world. The reactor will need to be readjusted as the resonant circuit will also change if the system parameters change.

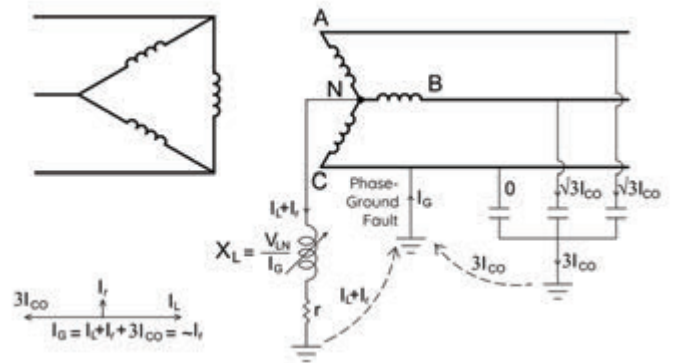
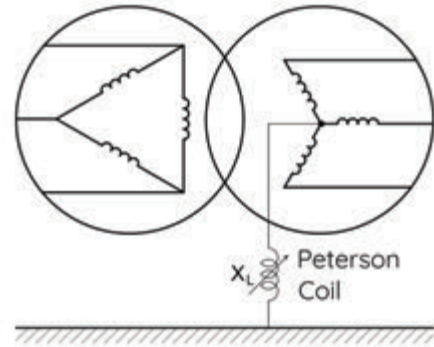

Solidly Grounded System

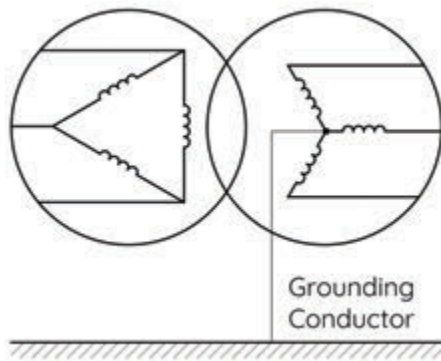

Solid grounding refers to the connection of a system conductor, usually the neutral of a generator, power transformer, or grounding transformer directly to ground, without any intentional intervening impedance. However, both the impedance of the source and the unintentional impedance in the connection to ground must be considered when evaluating the grounding.

This system is used when the magnitude of the single-phase earth fault current of the system is at least 60% of the three-phase fault current.

Because the reactance of a solidly grounded generator or transformer is in series with the neutral circuit, a solid connection does not provide a zero-impedance circuit. If the reactance of the system zero-sequence circuit is too great with respect to the system positive-sequence reactance, the objectives sought in grounding, principally freedom from transient overvoltages, may not be achieved. It may also not provide desired suppression of voltage to ground on the unfaulted phases.

This is rarely a problem in typical industrial and commercial power systems. One of these conditions is a power system fed by several generators and/or transformers in parallel. If the neutral of only one source is grounded, it is possible for the zero-sequence impedance of the grounded source to exceed the effective positive-sequence impedance of the several sources in parallel.

It is recommended for use in low voltage systems below 600 V where the fault currents of the solidly grounded systems are within acceptable limits or for high voltage systems above 36 kV.

Grounding System Through a Transformer

Neutral Grounded System Through a Single-Phase Transformer and a Resistor

A single-phase grounding transformer and neutral grounding resistor are used together in this system. This system is particularly suitable for grounding of generators. Because this system behaves normally as a non-grounded system but limits the fault current when a phase to ground fault occur. The primary winding of the grounding transformer is connected to the neutral winding of the system and Neutral grounding resistor is connected to the secondary winding of grounding transformer.

In this system, the fault current is usually limited a fault current less than 15 A on the primary side of the grounding transformer. The fault duration is usually 1 minute. The system therefore functions as a high-resistance neutral grounding.

The primary voltage value of the grounding transformer is up to the phase-neutral voltage of the system. The secondary voltage value is usually designed as 240 V, 120 V. In this way, the neutral grounding resistance is advantageous in terms of volume and therefore price, since it will be produced at low voltage, which is the secondary value of the earthing transformer, rather than the phase-neutral system voltage.

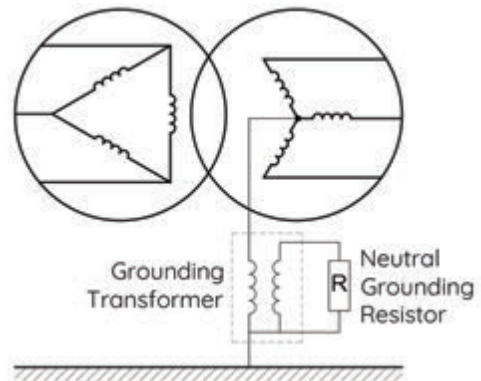

Obtain the System Neutral with Zig-zag Transformer

In the case of delta-connected systems with no neutral point or if the neutral point cannot be reached in some way, an earthing transformer is used to create an artificial neutral point and system can be grounded via this neutral point. Most grounding transformers are designed to be exposed to fault current below 1 min (usually 10 s), so they are much smaller in size than an ordinary three-phase continuously rated transformer with the same rating and cheap. One of these grounding transformers is zig-zag transformers.

In Zig-zag transformers, the phases are made with 6 windings and 2 windings per phase are connected to reverse phase to provide high impedance to the phase currents. The transformer impedance to zero-sequence voltages, however, is low so that it allows high ground-fault currents to flow. The transformer divides the ground-fault current into three equal components; these currents are in phase with each other and flow in the three windings of the grounding transformer. Zig-zag transformers have not got a secondary winding and a neutral point is obtained because the windings are connected according to the Wye configuration. This neutral point can be grounded through a resistor.

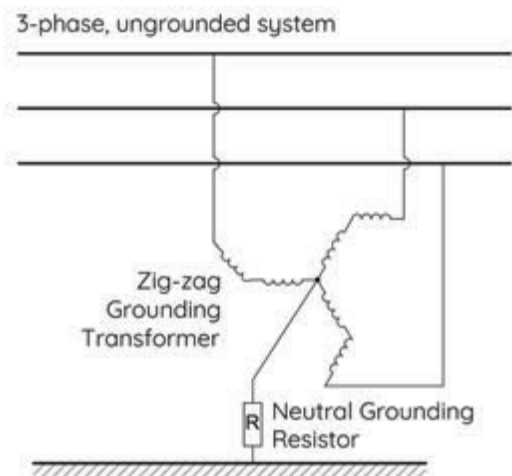

Grounding System Through a Transformer

Obtain the System Neutral with Wye-Delta Transformer

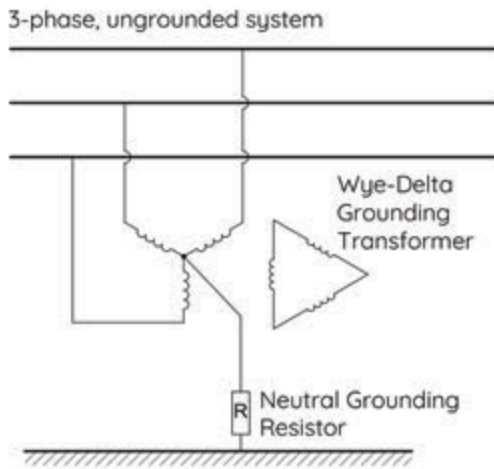

A wye - delta connected three-phase transformer or transformer bank can also be utilized for system grounding. The primary phase windings are connected to the phases of the system and the neutral point is connected directly or via a resistance to the ground. The delta connection must be closed to provide a path for the zero-sequence current, and the delta voltage rating is selected for any standard value.

When a phase neutral fault occurs, the fault current is limited to the sum of the transformer leakage reactance and neutral resistance as the transformer has zero sequence in the primary Wye windings and the secondary delta is a closed series circuit.

- The voltage rating of the wye winding shall not be less than the normal line-to-line system voltage.
- Wye-delta grounding transformer should be connected between the secondary terminals of the system's power transformer and the main circuit breaker as close as possible to the power transformer.
- If there is more than one power transformer in the system, a separate grounding transformer must be connected for each. However, it should be ensured that there is only one earthing transformer in the same section of the system.

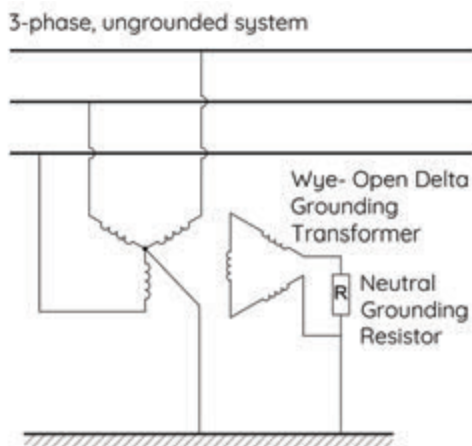

Obtain the System Neutral with Wye - Open Delta Transformer

In this application, the neutral side of the primary of the Wye - open delta earthing transformer is directly connected to the ground. A limiting resistor is connected to the open ends of the open delta connected secondary windings. When a phase earth fault occurs in the system, this resistance limits the current in closed secondary delta windings. In this way, the fault current in the primary windings of the earthing transformer is also limited.

Other Neutral Grounding Resistance Applications

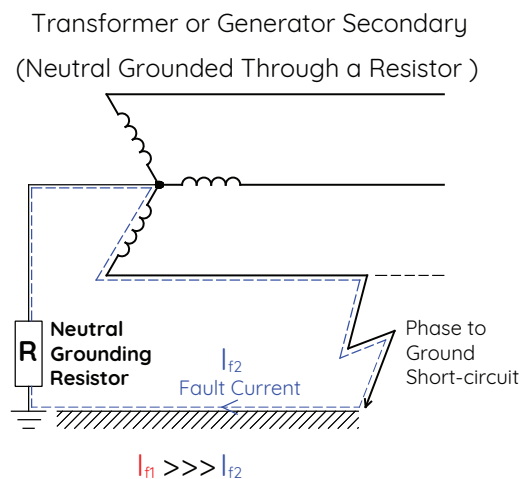
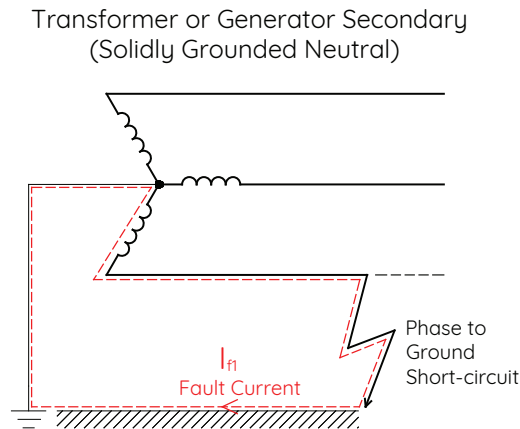

On LV and MV distribution networks, neutral points of power transformers and generators are grounded through a resistor. The purpose of Neutral Grounding;

- Limit the ground fault current to prevent any damage to the transformer and the generator and ensure operation continuity and safety
- Provide sensing the fault current with the relays by means of current transformer mounted inside the Neutral Grounding Resistor and limiting the fault duration. Limit oscillating and non-oscillating transient voltage caused by the interruption of the failure current and so protect the insulation level of system equipment
- Improve personnel safety by ensuring that the step voltage on the site is maintained at safety levels Prevent overheating and mechanical stress on the equipment subject to failure current

Phase-ground short-circuit current of the transformer and the generator is calculated to determine the limit current of the neutral grounding resistor. The resistor is designed to limit the failure current to 10% of this short-circuit current. The limiting current for the transformer or generator can be selected up to the rated current in case of the short-circuit current cannot be calculated. This value shall be optimal to allow detection of the selected limited fault current value by the relays. Therefore, primary value of the current transformers used on the neutral grounding resistor can be different from the limited fault current value.

Fault duration is generally 5 – 10 seconds. This can be up to 30 seconds at plants which do not have any tolerance to sudden power interruptions. At hospitals, data centers, textile plants, cement plants and other facilities that manufacture with injection, fault duration can be continuous unless the fault current do not damage the system to ensure continuity of system and determine the fault point without any power interruption. See “High-Resistance Neutral Grounding System” for detailed information.

The following basic parameters and a single-line scheme of the system, if possible, are required for preparing an offer for a neutral grounding resistor.

- Phase to phase and phase to neutral voltage of the transformer or generator to which the resistor is connected
- Fault current level
- Fault duration

Other Neutral Grounding Resistance Applications

Generator Neutral Cubicle & Generator Leads Cubicle

3 phases from the LV and MV generator are combined inside the Generator Neutral Cubicles to provide a neutral point. This neutral point is connected to the ground through a resistor. The difference from the standard neutral grounding resistance application is that the 3-phase current can be monitored.

Generator Leads Cubicles are used to monitor the current and voltage values in 3 phases of the energy produced in the generator and to receive feedback by the excitation transformer and also have some protections such as surge arrester.

High-Resistance Neutral Grounding System

High Resistance Grounding Systems (HNGR) are used that are limit the fault current up to 5 – 10 A at hospitals, data centers, textile plants, cement plants and other facilities that manufacture with injection to ensure continuity of system. These systems are designed to withstand the fault current continuously.

When determining the fault current in the HNGR system, it is necessary to take into account the capacitive currents and leakage currents flowing from the neutral to the ground due to the capacity of the cables. If the failure current is lower than the zero-sequence current, HNGR system runs in failure mode and cannot function.

HNGR systems are optimum solutions from 400 V to 6.9 kV medium voltage system.

One of the most important features of HNGR systems is the possibility of detecting the location of the fault. When a phase-to-earth fault occurs in the network, the HNGR system automatically reduces the resistance value by half, so as to flow twice the rated fault current for 1 second (E.g. 1 second 5A, 1 second 10 A). In this way, the fault current changes in such a way that the current can be easily detected even in high phase current and the currents of the outputs in the distribution panels are controlled with the help of a simple clamp meter and fault location is determined.

In contrast to other systems, Aktif HNGR systems automatically detect the location of fault. In the active control panel of the active brand HNGR, if there is a fault in the operation, it is automatically displayed from which distribution point of the fault and from the load which is connected to that distribution point. If the switching equipment used at the plant have the ability to receive the external interrupt signals, the source of the failure can be deactivated.

Also, Aktif HNGR systems automatically monitor and confirm that the system is functional. In case of a system failure, visual and audio alarms are sent to the user. Thus, it maximizes both its own an operational safety.

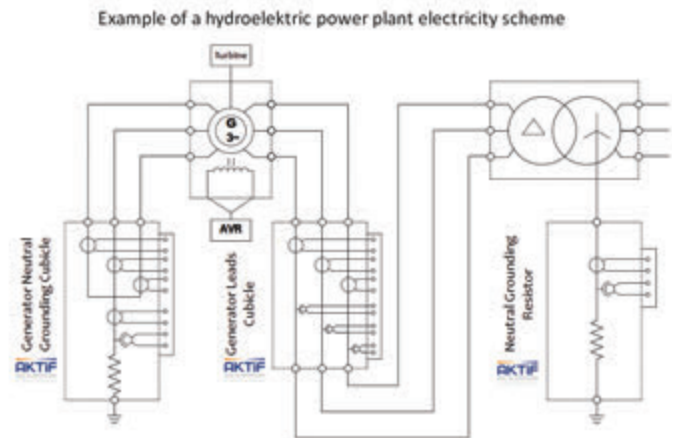

Other Neutral Earthing Resistance Applications

Neutral Resistor Monitoring System

Neutral Resistor Monitoring system are used with monitoring relays (continuity relays) which detect loose or broken resistor connections in products which limit phase to ground fault currents such as neutral grounding resistors, high-resistance neutral grounding systems and generator neutral cubicles.

One of Sensing resistor terminal is connected to the neutral point which passes through the neutral current transformer (parallel with the neutral resistor) and the other terminal is connected to the monitoring relay. The monitoring relay sends the low-amplitude high-frequency signal to the neutral resistor through the sensing resistor and reads the current and voltage at the neutral point. In this way the resistance of the neutral grounding resistor is controlled continuously, and a warning and/or trip signal is sent in case of a resistance different than the set value.

Aktif sensing resistors are manufactured and tested according to insulation of the network and monitoring relay.

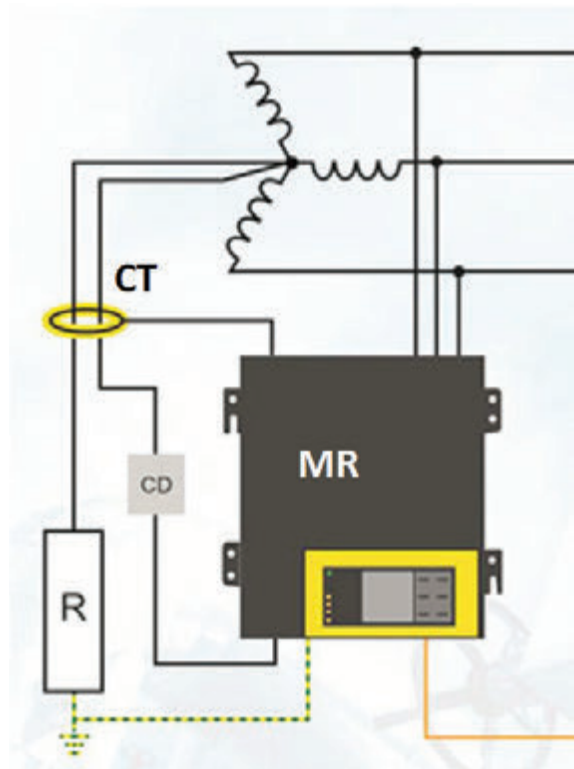

Technical Specifications:

- Suitable up to 110/ $\sqrt{3}$ kV
- Applicable for fault currents up to 5000 A
- Stainless steel resistance material suitable for extreme ambient conditions, resistant to oxidation and corrosion (AISI304, AISI310, AISI316, AISI430, CrAl, CrNi)
- Special mechanical and electrical design to withstand high temperature and extreme current values
- Internal current transformer detecting failure current
- Design and tests in accordance with ANSI-IEEE 32 standard and special specifications

Neutral Resistor Monitoring System	
MR	Monitoring Relay
CD	Sensing Resistor
CT	Current Transformer
R	Neutral Grounding Resistor

Resistor Element:

- Spring-wound, edge-wound or grid resistor elements with a cross-section suitable for the nominal current
- Fully-modular, banded and stainless steel bolt connections in order to ensure electrical continuity at high temperature High conductivity for high current with banded and cascaded terminal connectors suitable for serial and/or parallel connections with high cross-section, low contact resistance
- High internal insulation and high mechanical resistance against to shocks and sagging thanks to the use of large surface sated bushings and M16 shear connectors
- Special designed to dissipate the thermal and mechanical effects of overcurrent to the surface grid resistors



GR_01 (Izgara Direnç Bloğu)

Other Neutral Earthing Resistance Applications

Enclosure:

- Standard IP23 Protection Level suitable for outdoor usage and perfect cooling
- IP 65 terminal box
- Standard hot-dipped galvanized steel
- Fully-modular, rigid, strong enclosure design with resistor blocks mounted to the frame for safety lifting from the upper or lower side
- Easy access to and maintenance for resistor blocks on site thanks to blocks independently mounted to the frame, no overlapping
- Lockable door with hinges
- Corrosion-resistant handling rings and connectors
- Stainless Steel product and warning labels

Options:

- Requested protection level from IP00 to IP56
- Stainless Steel ,aluminum enclosure
- Painting enclosure in desired color code
- Entry from top or bottom with bushings
- Additional equipment including separators, voltage transformer, grounding transformer, surge arrester, relay, panel heater etc.
- Modular elevation legs suitable for extreme environmental conditions
- Special design for high altitude
- Special design suitable for explosive environments (ATEX)



Spring Wound Resistor Element



Edge Wound Resistor Element

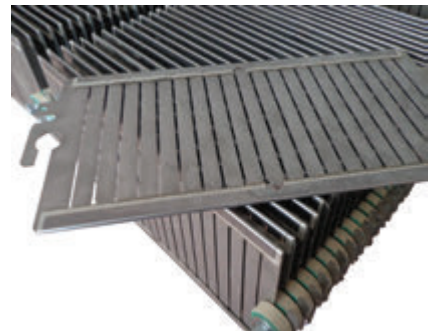

Grid Resistor Element



Characteristic of grounding methods (comparison summary)

	Fault Current*	Temporary over-voltage suppression	Failure detection	Service continuity	Recommended Use
Ungrounded System	Less than %1	Poor	Poor	Good	Not Recommended
Low-Resistance Grounding	$\leq 20\%$ (-100-1000A) (Medium)	Good	Good	Poor	2,4 - 36 kV
High-Resistance Grounding	$< 1\%$ and $> 3I_{CO}$ (Low)	Good	Good	Good	$< 6,3$ kV
Low-Reactance Grounding	$25\% - 100\%$ (High)	Good	Good	Poor	< 600 V and > 36 kV
High-Reactance Grounding	$5\% - 25\%$ (Medium)	Poor	Good	Poor	Not Recommended
Ground-Fault Neutralizer (Petersen Coil)	Almost 0 (Low)	Good	Good	Poor	Medium Voltage System isolated from Utility
Solid Grounding	$> 100\%$ (High)	Good	Medium	Poor	< 600 V ve > 36 kV

*The ratio of single phase earth fault current to 3 phase fault current

Watt White!

White...

Color of the beginning...

White, color of the purity, honesty and clarity...

Color of the stability and continuity, trust and quality...

Since 2010, we decided to apply white color which symbolizes all of these values to all of our products.

Switchgears and Substations

Metal Enclosed Switchgears

Metal Clad Switchgears

Mobile Substations

E-House / Compact Substations

Power Resistors

Grounding Resistors

Load Banks

Filter Resistors

Motor Control & Braking Resistors

Power Quality & Power Factor Correction

LV Capacitor & Filter Banks

MV Capacitor & Filter Banks

Capacitors & Harmonic Filter Reactors

Thyristor Switches

Medical Power & Control Panels

Operating Room Control Panels

Isolated Power Panel

Isolation Transformers

Automatic Transfer Relays

Smart Grid

Energy Management Systems

Metering & Submetering

Power Analyzers & Quality Recorders

Protection Devices

Traction Substation

Traction Rectifiers

DC Switchgears

DC Disconnectors

Traction Transformers

Renewable Energy & DC Conversion

High Power Rectifiers

Solar Inverters

Energy Storage Systems

EV Charging Stations



Headquarters

Bayraktar Blv. Şehit sk. No: 5 Aktif Plaza
34775 Ümraniye İstanbul / Turkey
Tel : +90 (216) 314 93 20
Fax : +90 (216) 314 93 60
www.aktif.net - info@aktif.net

Switchgear Factory

Akşemsettin Mh. Çatalca sk. No:113
06930 Sincan Ankara / Turkey
Tel : +90 (312) 269 46 02
Fax : +90 (312) 269 45 01
www.aktif.net - info@aktif.net

Resistor Factory

Pirahmetler mh. D-100 Yanyol cd.
No:78/A Erenler 54200 - Sakarya / Turkey
Tel : +90 (264) 276 64 50
Fax : +90 (264) 276 64 52
www.aktif.net - info@aktif.net