

# Energy Analyzers and Meters



# Energy Analyzers and Meters

## Rail Type Energy Meters

The energy meters, “with a white back-lighted LCD screen for perfect reading,” are designed for single-phase and three-phase energy measurements in residential and utility applications. These devices measure and display various important electrical parameters and provide a communication port for remote reading and monitoring. The bi-directional energy measurement feature makes them an ideal choice for solar PV energy metering. Additionally, models with LoRa communication, as well as prepayment or generator tariff options, are also available.

### Application Areas

- Shopping Malls
- Marinas
- Residences
- Airports
- Factories
- Holiday Villages
- Penal institutions
- EV Chargers

### Advantages

- Class 0.5 and Class 1 applications
- Competitive prices

- Compatibility with all software through Modbus RTU protocol communication
- Measurement capability up to 100 Amperes
- Bidirectional measurement capability
- Occupies less space compared to competitors
- Higher measurement accuracy classes
- Wide measurement range
- Billing of high-cost liquid fuels with generator tariff option
- Easy collection of payments from subscribers with prepaid types and the advantage of upfront payment collection
- Din Rail mounting (35mm)
- Wide solution capability with direct and current transformer models
- RS485(Modbus) or Wireless data transmission via LoRaWAN communication
- No cable and labor costs
- Fewer failure points compared to wired systems due to wireless feature
- Convertible to panel type with additional equipment (Just NDM70 series)
- White backlit LCD display
- Scrollable settings display
- Support for AMR, SCADA system
- Multifunction measurement
- Easy payment collection from subscribers (prepaid types)

**NDM30 Rail Type  
Single Phase Electricity Meter**



**NDM30 Lora Rail Type  
Single Phase Electricity Meter**



**NDM50 Rail Type  
Three Phase Electricity Meter**



**NDM50 Lora Rail Type  
Three Phase Electricity Meter**



**NDM70 Rail Type  
Three Phase Electricity Meter**



**NDM70 Lora Rail Type  
Three Phase Electricity Meter**



# Energy Analyzers and Meters

## NDM30 Rail Type Single Phase Electricity Meter

### Standarts

- IEC62053-21
- EN50470-1/3
- IEC62053-23
- EN61326-1:2013
- EN61326-2-3:2013
- EN 61010\_1:2010+A1:2019
- EN 61010-2-30-2010

### Features

- Operating temperature: -25°C to +55°C
- Storage/transport temperature: -40°C to +70°C
- Reference temperature: 23°C ± 2°C
- Relative humidity: 0% to 95%, non-condensing
- Installation category: CAT II
- Electromagnetic environment: M1
- Pollution degree: E2
- Power consumption: <2W/10VA
- Frequency: 50Hz
- AC voltage withstand: 4KV for 1 minute
- Impulse voltage withstand: 6KV-1.2μS waveform
- Overcurrent withstand: 30Imax for 0.01s
- Pulse 1 output rate: Configurable, default 1000i/kWh
- Pulse 2 output rate: Non-configurable, 1000i/kWh
- Display: Backlit LCD
- Maximum reading: 99999.99kWh
- Nominal Voltage(Un): 120V / 230 VAC

### Wiring Diagram

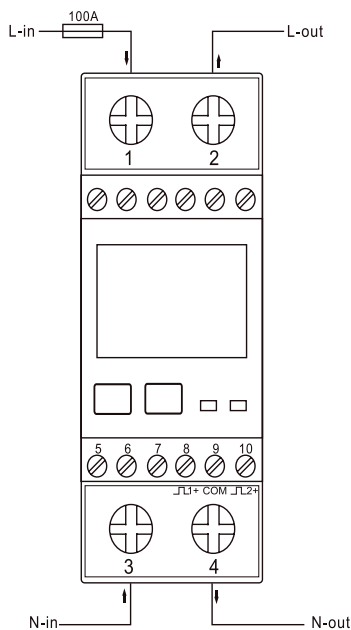

### Accuracy

- Voltage: 0.5%
- Current: 0.5%
- Frequency: 0.2%
- Active power: 1%
- Reactive power: 1%
- Apparent power: 1%
- Active energy: Class 1 IEC62053-21, Class B EN50470-3
- Reactive energy: 1%

### Environment

- Operating temperature: -25°C to +55°C
- Storage/transport temperature: -40°C to +70°C
- Reference temperature: 23°C ± 2°C
- Relative humidity: 0% to 95%, non-condensing
- Installation category: CAT II
- Electromagnetic environment: M1
- Pollution degree: E2

### Dimensions

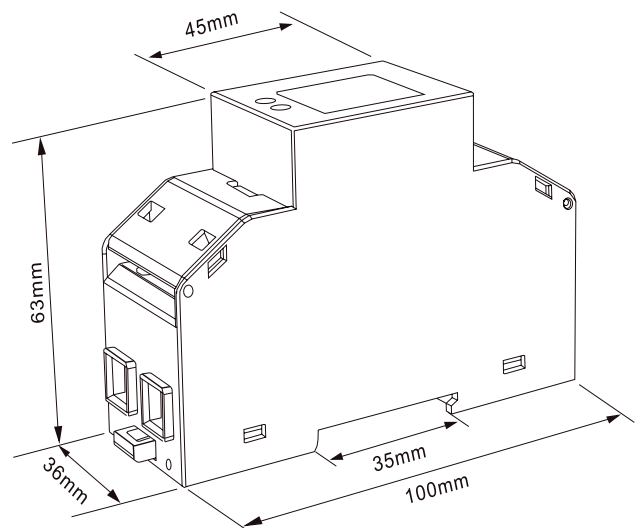

# Energy Analyzers and Meters

## NDM30 Lora Rail Type Single Phase Electricity Meter

### Standards and Protocols:

- International standards: IEC 62053-21/ EN50470-1/3
- Interface standard and protocol: LoRaWAN Specification 1.0.2
- Electromagnetic HF fields: IEC 61000-4-3
- Radiated and conducted emissions: EN55022
- Electromagnetic Compatibility: EN61326-1:2013 & EN61326-2-3:2013
- Low Voltage Directive: EN 61010\_1:2010+A1:2019 & EN 61010-2-30-2010

### Features

- Nominal voltage( $U_n$ ) 120V or 230V AC
- Operational voltage 80%-120% of  $U_n$
- Insulation capabilities
  - AC voltage withstand 4KV for 1 minute
  - Impulse voltage withstand 6KV-1.2 $\mu$ S
- Basic current( $I_b$ ) 10A
- Maximum rated current( $I_{max}$ ) 100A
- Operational current range 0.4%  $I_b$ - $I_{max}$
- Over current withstand 30  $I_{max}$  for 0.01s
- Operational frequency range 50 or 60Hz
- Internal power consumption  $\leq$  2W/10VA
- Pulse output 1 1000imp/kWh(configurable)
- Pulse output 2 1000imp/kWh
- Max reading 99999.99kWh

### Performance Criteria

- Voltage: 0.5%
- Current: 0.5%

### Wiring Diagram

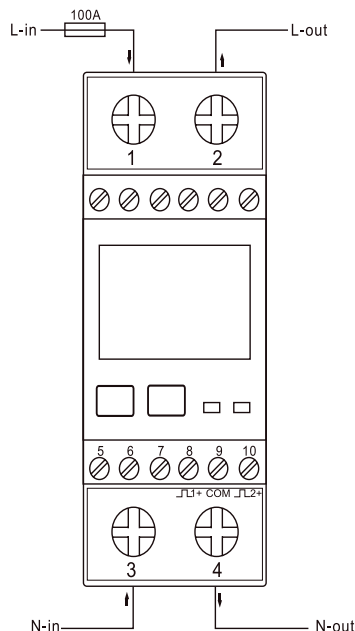

- Frequency: 0.2%
- Active power: 1%
- Reactive power: 1%
- Apparent power: 1%
- Active energy: Class 1 IEC62053-21, Class B EN50470-3
- Reactive energy: 1%

### Accuracy

- Voltage, Current:  $\pm$ 0.5%
- Frequency:  $\pm$ 0.2% of mid-frequency
- Power factor:  $\pm$ 1% of unity (0.01)
- Active power, Apparent power:  $\pm$ 1% of range maximum
- Reactive power:  $\pm$ 1% of range maximum
- Reactive energy (VARh): Class 2
- Active energy (Wh): Class 1

### Communication

- Interface Standard and Protocol: LoRaWAN Specification 1.0.2
- Frequency: EU868/AS923/AU915/US902/CN470/ CN433
- LoRaWAN Classes: Class C
- Automatic Upload: Max. 19 parameters
- Automatic Upload Interval: Configurable
- Activation Way: OTAA or ABP
- Output Power: 13dBm in transmission
- Coding Format: ASCII
- Communication Distance: 1500M in an open area

### Dimensions

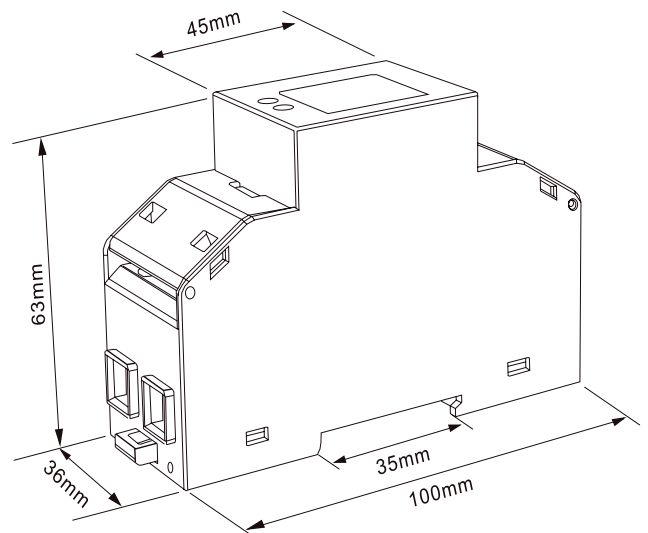

# Energy Analyzers and Meters

## NDM50 Rail Type Three Phase Electricity Meter

### Standards

- IEC62053-21
- IEC62053-22
- IEC62053-23

### Features

- Nominal voltage (Un): 3x230/400 V ac
- Operating voltage: 80%-120% of Un
- AC voltage fluctuations: 4kV for 1 minute
- Impulse voltage limit: 6kV-1.2μS
- Basic current (Ib): 10A
- Operating range: 0.4 Ib-I<sub>max</sub>
- Overcurrent fluctuation: 30 I<sub>max</sub> for 0.01 seconds
- Operational frequency range: 50 or 60Hz
- Internal power consumption: ≤ 2W/10VA
- Display: LCD
- Maximum reading: 999999.99kWh

### Performance Criteria

- Operating humidity: ≤ 90%, non-condensing
- Storage humidity: ≤ 95%, non-condensing
- Operating temperature: -25 to 55°C
- Storage temperature: -40 to 70°C
- Reference temperature: 23°C ± 2°C
- International standards: IEC 62053-22
- Accuracy class: Class 0.5S
- Installation category: CAT III
- Mechanical environment: M1
- Electromagnetic environment: E2
- Pollution degree: 2
- Protection against dust and water ingress: IP51 (indoor)

### Wiring Diagram

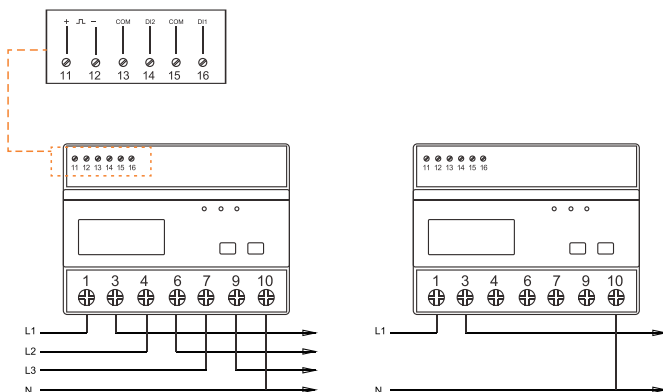

- Protective measurement device altitude: Class II
- Electrostatic insulation: 8kV contact / 15kV air discharge
- Electromagnetic HF fields: IEC 61000-4-3
- Electrical fast transients: 4kV

### Accuracy

- Voltage, Current: ±0.2%
- Frequency: ±0.2% of the nominal frequency
- Power factor: ±1% of unity (0.01)
- Active power, Apparent power: ±5% of the maximum range
- Reactive power: ±1% of the maximum range
- Reactive energy (VARh): Class 2
- Active energy (Wh): Class 0.5S / Class 1.0

### Pulse Output

- Pulse output: 1
- Pulse output type: Passive
- Pulse output 1: Configurable
- Pulse width: 200/100 (default) / 60ms

### Dimensions

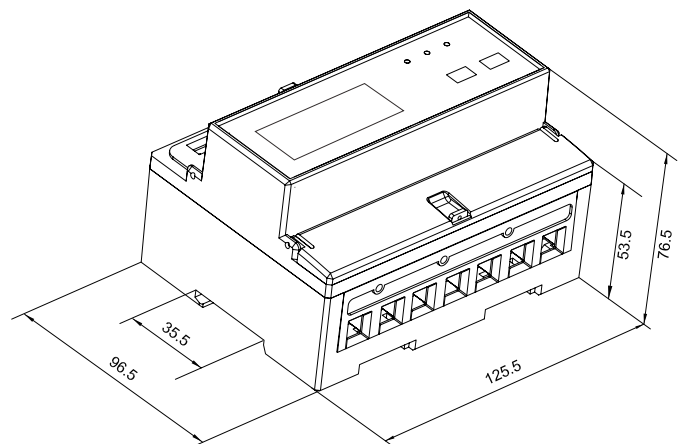

# Energy Analyzers and Meters

## NDM50 Lora Rail Type Three Phase Electricity Meter

### Standards and Protocols:

- IEC62053-21
- IEC62053-22
- IEC62053-23
- EN61326-1:2013
- EN61326-2-3:2013
- EN 61010\_1:2010+A1:2019
- EN 61010-2-30-2010

### Features

- Nominal voltage(Un): 3x230/400 V ac
- Operational voltage: 80%-120% of Un
- Insulation capabilities:
  - AC voltage withstand: 4KV for 1 minute
  - Impulse voltage withstand: 6KV-1.2μS
- Basic current (Ib): 10A
- Operational current range: 0.4% Ib-I<sub>max</sub>
- Over current withstand: 30 I<sub>max</sub> for 0.01s
- Operational frequency range: 50 or 60Hz
- Power consumption per phase: ≤ 2W/10VA
- Display: LCD
- Max reading: 999999.99 kWh/kVarh

### Performance Criteria

- Operating humidity: ≤ 90%, non-condensing
- Storage humidity: ≤ 95%, non-condensing
- Operating temperature: -25 to 55°C
- Storage temperature: -40 to 70°C
- Reference temperature: 23°C ± 2°C
- International standard: IEC 62053-22
- Accuracy class: Class 0.5S
- Installation category: CAT III
- Mechanical environment: M1
- Electromagnetic environment: E2
- Pollution degree: 2
- Protection against dust and water ingress: IP51 (indoor)

### Wiring Diagram

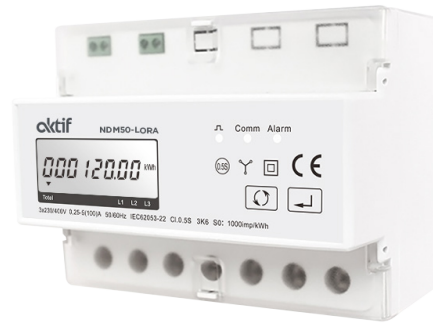
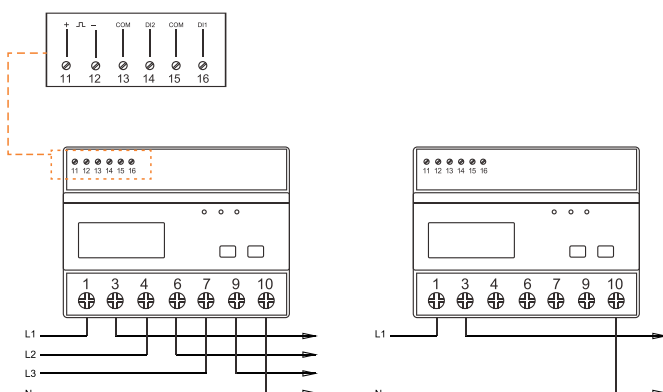

- Protective insulated meter: Class II
- Electrostatic discharges: 8kV contact / 15kV air gap
- Electromagnetic HF fields: IEC 61000-4-3
- Electrical fast transients: 4kV

### Accuracy

- Voltage, Current: ±0.2%
- Frequency: ±0.2% of the nominal frequency
- Power factor: ±1% of unity (0.01)
- Active power, Apparent power: ±5% of the maximum range
- Reactive power: ±1% of the maximum range
- Reactive energy (VArh): Class 2
- Active energy (Wh): Class 0.5S / Class 1.0

### Communication

- Interface Standard and Protocol: LoRaWAN Specification 1.0.2
- Frequency: EU868/AS923/AU915/US902/CN470/CN433
- LoRaWAN Classes: Class C
- Automatic Upload: Supported
- Automatic Upload Interval: Configurable

### Pulse Output

- Pulse output: 1
- Pulse output type: Passive
- Pulse output 1: Configurable
- Pulse width: 200 / 100 (default) / 60ms

### Dimensions

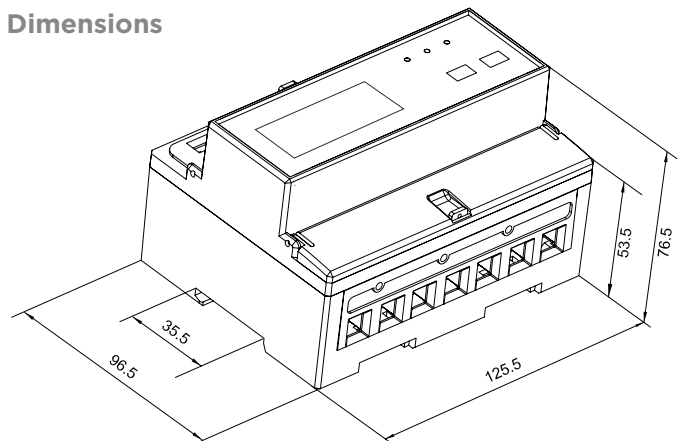

# Energy Analyzers and Meters

## NDM70 Rail Type Three Phase Electricity Meter

### Standarts

- IEC62053-21
- EN50470-1/3
- EN61326-1:2013
- EN61326-2-3:2013
- EN 61010\_1:2010+A1:2019
- EN 61010-2-30-2010

### Accuracy

- Active Power:  $\pm 1\%$  of the maximum range
- Reactive Power (VAR):  $\pm 1\%$  of the maximum range
- Apparent Power (VA):  $\pm 1\%$  of the maximum range
- Active Energy: IEC62053-21 Class 1.0
- Reactive Energy: IEC62053-23 Class 2, IEC61557-12 Class 2
- Frequency:  $\pm 0.2\%$
- Current:  $\pm 0.5\%$
- Voltage:  $\pm 0.5\%$
- Power Factor:  $\pm 0.01$
- Data Update Rate: Nominal 1 second
- Power Consumption per Phase:  $\leq 2W/10VA$
- Maximum Reading: 999999.99 kWh/kvarh
- Nominal Voltage( $U_n$ ): 3x230 / 400 VAC



### Environment

- Operating Temperature: -25 to 55°C
- Storage Temperature: -40 to 70°C
- Humidity Level: <95% RH at 50°C (non-condensing)
- Pollution Degree: 2
- Altitude: 2000m

### Wiring Diagram

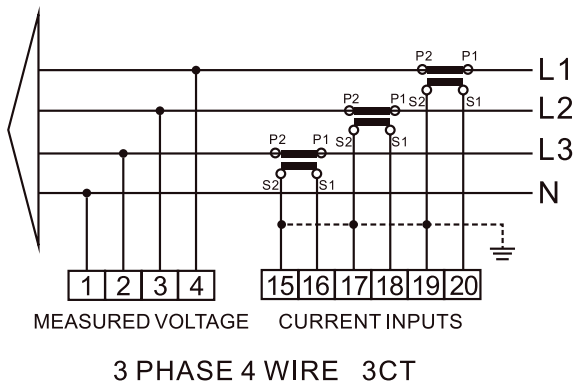

### Dimensions

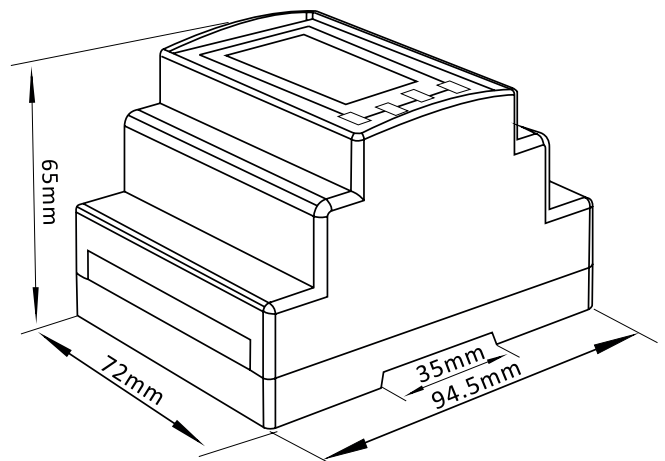

# Energy Analyzers and Meters

## NDM70 Lora Rail Type Three Phase Electricity Meter

### Standards and Protocols:

- IEC 62053-21
- IEC 62053-23
- EN50470-1/3
- EN61326-1:2013
- EN61326-2-3:2013
- EN 61010\_1:2010+A1:2019
- EN 61010-2-30-2010

### Features

- VT Primary: 30 ~ 500,000 Vac
- Un: 230 V L-N
- Voltage Measured with Overrange: 173 to 480 V AC L-L / 100 to 276 V AC L-N
- Impedance: 1M $\Omega$
- Frequency Range: 45~65Hz
- CT Ratings
  - Primary: 1-9999A
  - Secondary: 1A / 5A
- Current Measured with Overrange: 6A
- Endurance: Continuous 120A for 0.5 seconds
- Impedance: < 1M $\Omega$
- Frequency Range: 45~65Hz
- Load: < 0.036VA at 6A
- Measured Voltage: 173 / 480 VAC L-L  
100 / 276 VAC L-N

### Accuracy

- Active Energy: IEC 62053-21 Class 1 / EN50470-1/3
- Reactive Energy: IEC 62053-23 Class 2
- Frequency:  $\pm 0.2\%$
- Current:  $\pm 0.5\%$
- Voltage:  $\pm 0.5\%$
- Power:  $\pm 0.01$

### Wiring Diagram

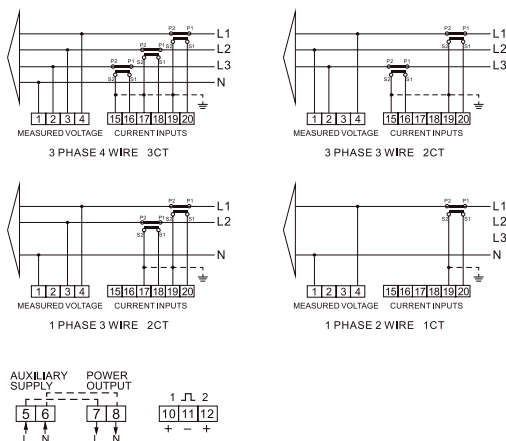

- Power Factor:  $\pm 0.01$

### Communication

- Interface standard and protocol: LoRaWAN Specification 1.0.2
- Frequency: EU868/AS923/AU915/US902/CN470/CN433
- LoRaWAN Classes: Class C
- Automatic upload: Max. 30 parameters
- Automatic upload interval: Configurable
- Activation method: OTAA or ABP
- Output power: 13dBm during transmission
- Encoding format: ASCII
- Communication range: 1500m in open space

### Environment

- Operating Temperature: -25 to 55°C
- Storage Temperature: -40 to 70°C
- Humidity Level: < 95% RH at 50°C (non-condensing)
- Pollution Degree: 2
- Altitude: 2000m
- Vibration: 10Hz to 50Hz, IEC 60068-2-6

### Dimensions

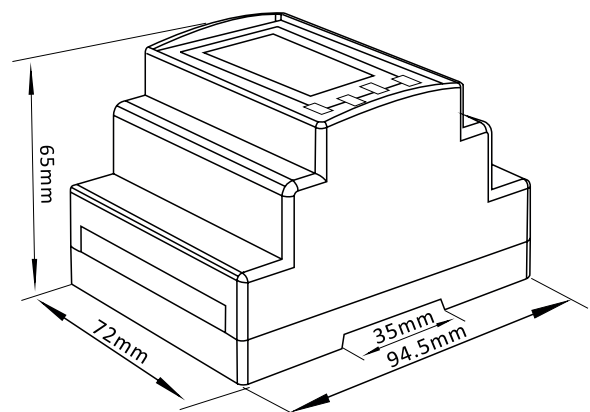

# Energy Analyzers and Meters

## Panel Type Energy Analyzers

Energy analyzers are designed to measure key electrical parameters such as Voltage (V), Current (A), Frequency (Hz), Power Factor (PF), Active, Reactive, and Apparent Power (kW/kVA/kVAR).

They also measure Import, Export, and Total Active and Reactive Energy (kWh/kVARh).

The measured parameters can be transmitted to SCADA and energy management systems via various communication interfaces, such as RS485 Modbus-RTU and Ethernet Modbus-TCP.

Energy analyzers are compatible with 1A or 5A Current Transformers (CT) and can be configured to work with a wide range of CTs. They can also be configured to work with a voltage transformer.

The devices offer digital inputs, digital outputs, pulse outputs, and RS485 Modbus RTU communication without the need for additional modules.

Instead of programming via Modbus, the device features a password-protected setup menu within the device software, allowing configuration without the need for communication-based integration.

Energy analyzers do not require a separate auxiliary power supply for operation.

The auxiliary power is drawn from any of

the voltage inputs, ensuring that if one phase fails, the device will continue to measure by drawing power from another phase.

### Application Areas

- Shopping Malls
- Organized Industrial Zones
- Electrical Panel Manufacturing
- Marinas
- Residences
- Airports
- Factories
- Resorts

### Advantages

- Suitability for panel type application solutions
- Class 0.5 and class 1 applications
- Competitive prices
- Compatibility with all software through Modbus RTU protocol communication
- Direct Ethernet connection feature with Ethernet output models
- Bidirectional measurement capability
- Scaled display by entering the ratios of current transformers to which it is electrically connected into the interface
- AC/DC supply capability with auxiliary supply terminal
- Different electrical connection options for TT and TN
- Optional multi-tariff
- Pulse output feature

**NPM270BX Series Panel Type Energy Analyzers**



**NPM270BX-ETH Series Panel Type Energy Analyzers**



**NPM290-5G Series Panel Type Energy Analyzers**



**NPM290-5J Series Panel Type Energy Analyzers**



# Energy Analyzers and Meters

## NPM270BX Series Panel Type Energy Analyzers

### Standards

- IEC 62053-21
- IEC62053-23
- EN61326-1:2013
- EN61326-2-3:2013
- EN 61010\_1:2010+A1:2019
- EN 61010-2-30-2010

### Features

- Multi-parameter measurement
- Individual harmonic distortion from 2nd to 63rd
- Supports 3p4w, 3p3w, 1p2w systems
- Current transformer (CT) and voltage transformer (PT) connection
- RS485 Modbus communication
- Pulse output
- Multiple tariffs available
- Auxiliary Power: 65-275 VAC / 80-380 VDC

### Outputs

- Pulse width: 60 / 100 / 200 ms
- SO pulse rate: 0.01 / 0.1 / 1 / 10 / 100 kWh/kVArh
- SO 2 pulse output (non-configurable): 3200IMP/kWh
- Communication: Modbus RTU (RS485)
- Input Voltage: 3x230 / 400 VAC

### Accuracy

- Voltage (V):  $\pm 0.5\%$  of the maximum range
- Current (A):  $\pm 0.5\%$  of the maximum range
- Frequency (Hz):  $\pm 0.2\%$  of the nominal frequency
- Power Factor (PF):  $\pm 1\%$  of unity (0.01)
- Active Power (W):  $\pm 1.0\%$  of the maximum range
- Reactive Power (VAr):  $\pm 1.0\%$  of the maximum range

### Wiring Diagram

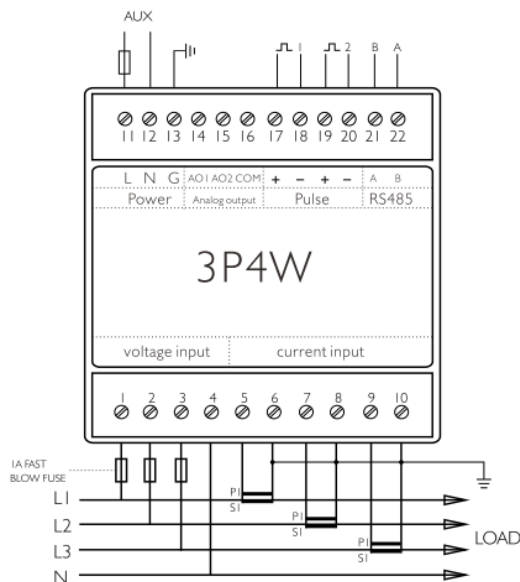

- Apparent Power (VA):  $\pm 1.0\%$  of the maximum range
- Active Energy (kWh): Class 1, according to IEC 62053-21 standard
- Reactive Energy (kVArh): Class 2, according to IEC 62053-23 standard
- THD: Total harmonic distortion for 2nd to 63rd harmonics

### Environment

- Operating temperature:  $-25^{\circ}\text{C}$  to  $+55^{\circ}\text{C}$
- Storage temperature:  $-40^{\circ}\text{C}$  to  $+70^{\circ}\text{C}$
- Relative humidity: 0% - 95%, non-condensing
- Shock: 30g in 3 planes
- Vibration: 10Hz - 50Hz, according to IEC 60068-2-6 standard, 2g
- Dielectric voltage: 4kV between ground, voltage, and current
- Altitude: Up to 2000 meters
- Warm-up time: 5 seconds

### Dimensions

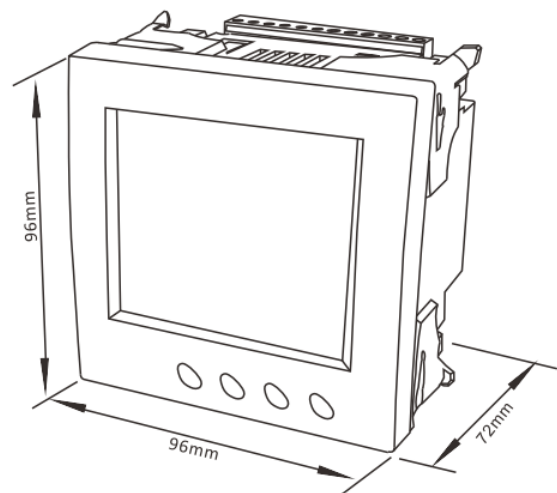

# Energy Analyzers and Meters

## NPM270BX-ETH Series Panel Type Energy Analyzers

### Standards

- IEC61557-12
- IEC 62053-22
- IEC 62053-23
- IEC61000-3-2
- IEC61000-4-2,3,4,5,6,8,11
- EN55011 Class A
- EN61326-1:2013
- EN61326-2-3:2013
- EN 61010\_1:2010+A1:2019
- EN 61010-2-30-2010



### Features

- Multi-parameter measurements
- THD and IHD up to the 63rd harmonic
- RS485 Modbus RTU
- Ethernet TCP gateway
- Multiple tariffs
- Accuracy class 0.5s
- Bar graph for power indication
- Backlit LCD screen for wide viewing angle
- Plug-and-play installation and connection
- Measured Voltage: 50 to 600 Vac L-L  
50 to 345 Vac L-N
- Auxiliary Power: 85~275V AC / 120~380 VDC

### Accuracy

- Voltage (L-N / L-L):  $\pm 0.5\%$  of the maximum range
- Power: IEC 61557-12 Class 0.5
- Active energy: IEC 62053-22 Class 0.5S, IEC 61557-12 Class 0.5S

- Reactive energy: IEC 62053-23 Class 2, IEC 61557-12 Class 2
- Frequency:  $\pm 0.1\%$
- Current:  $\pm 0.2\%$
- Voltage:  $\pm 0.2\%$
- Power factor:  $\pm 0.01$
- Harmonic distortion: 2

### Environment

- Operating temperature:  $-25^{\circ}\text{C}$  to  $+55^{\circ}\text{C}$
- Storage temperature:  $-40^{\circ}\text{C}$  to  $+70^{\circ}\text{C}$
- Humidity:  $< 95\%$  relative humidity at  $50^{\circ}\text{C}$  (non-condensing)
- Pollution degree: 2
- Altitude: Up to 3000 meters
- Vibration: 10Hz - 50Hz, according to IEC 60068-2-6 standard

### Wiring Diagram

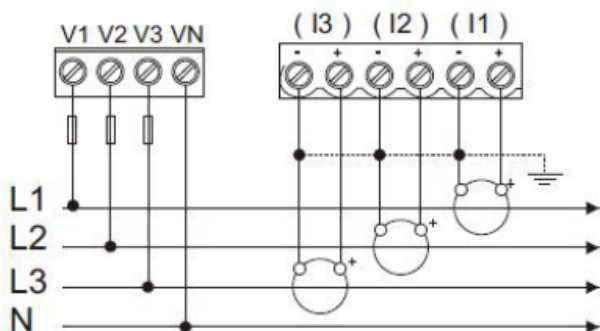

### Dimensions

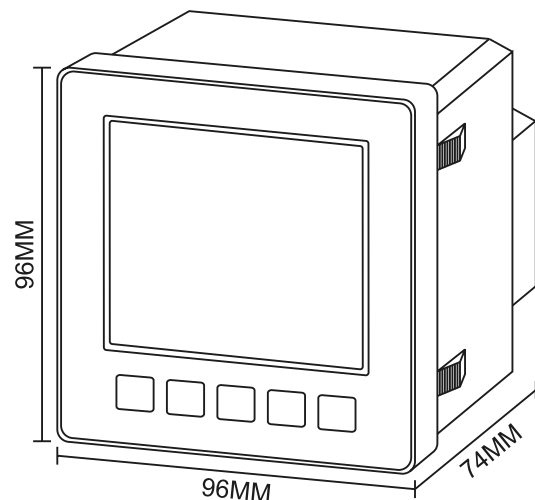

# Energy Analyzers and Meters

## NPM290-5G Series Panel Type Energy Analyzers

### Standards

- IEC61557-12
- IEC 62053-22
- IEC 62053-23
- IEC61000-3-2
- IEC61000-4-2,3,4,5,6,8,11
- EN55011 Class A
- EN61326-1:2013
- EN61326-2-3:2013
- EN 61010\_1:2010+A1:2019
- EN 61010-2-30-2010

### Features

- Multi-parameter measurements
- THD and IHD up to the 63rd harmonic
- RS485 Modbus RTU
- Digital input/output
- Multiple tariffs
- Accuracy class 0.5s
- Bar graph for power indication
- Backlit LCD screen for wide viewing angle
- Plug-and-play installation and connection
- Measured Voltage: 50 to 600 Vac L-L  
50 to 345 Vac L-N
- Auxiliary Power: 85-275V AC / 120-380 VDC

### Accuracy

- Voltage (L-N / L-L):  $\pm 0.5\%$  of the maximum range
- Power: IEC 61557-12 Class 0.5
- Active energy: IEC 62053-22 Class 0.5S, IEC 61557-12 Class 0.5S
- Reactive energy: IEC 62053-23 Class 2, IEC 61557-12 Class 2
- Frequency:  $\pm 0.1\%$
- Current:  $\pm 0.2\%$
- Voltage:  $\pm 0.2\%$
- Power factor:  $\pm 0.01$
- Harmonic distortion: 2

### Wiring Diagram

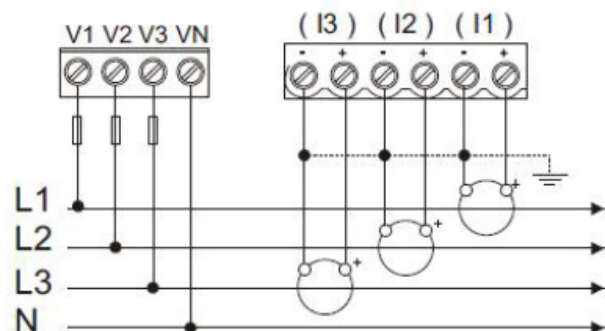

### Environment

- Operating temperature:  $-25^{\circ}\text{C}$  to  $+55^{\circ}\text{C}$
- Storage temperature:  $-40^{\circ}\text{C}$  to  $+70^{\circ}\text{C}$
- Humidity:  $< 95\%$  relative humidity at  $50^{\circ}\text{C}$  (non-condensing)
- Pollution degree: 2
- Altitude: Up to 3000 meters
- Vibration: 10Hz - 50Hz, according to IEC 60068-2-6 standard

### Digital Inputs

- Operating temperature:  $-25^{\circ}\text{C}$  to  $+55^{\circ}\text{C}$
- Count: 4
- Input resistance:  $10\ \Omega$
- Maximum frequency: 1kHz
- Response time: 10 milliseconds
- Insulation: 2.5 kV AC for 1 minute

### Digital outputs

- Operating temperature:  $-25^{\circ}\text{C}$  to  $+55^{\circ}\text{C}$
- Count/Type: 2 - Electromagnetic relay
- Output frequency: Maximum 1 Hz
- Switching current: 3.0 Amper at 250 VAC (100,000 cycles)
- Insulation: 2.5 kV AC for 1 minute

### Dimensions

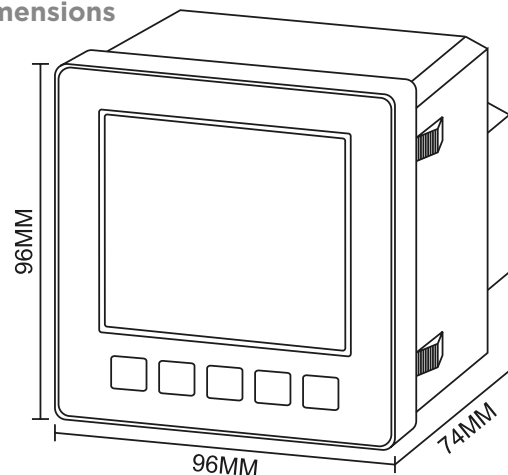

# Energy Analyzers and Meters

## NPM290-5J Series Panel Type Energy Analyzers

### Standards

- IEC61557-12
- IEC 62053-22
- IEC 62053-23
- IEC61000-3-2
- IEC61000-4-2,3,4,5,6,8,11
- EN55011 Class A
- EN61326-1:2013
- EN61326-2-3:2013
- EN 61010\_1:2010+A1:2019
- EN 61010-2-30-2010

### Features

- Multi-parameter measurements
- THD and IHD up to the 63rd harmonic
- RS485 Modbus RTU
- Ethernet TCP gateway
- Digital input/output
- Multiple tariffs
- Accuracy class 0.5s
- Bar graph for power indication
- Backlit LCD screen for wide viewing angle
- Plug-and-play installation and connection
- Measured Voltage: 50 to 600 Vac L-L  
50 to 345 Vac L-N
- Auxiliary Power: 85~275V AC / 120~380 VDC

### Accuracy

- Voltage (L-N / L-L):  $\pm 0.5\%$  of the maximum range
- Power: IEC 61557-12 Class 0.5
- Active energy: IEC 62053-22 Class 0.5S, IEC 61557-12 Class 0.5S
- Reactive energy: IEC 62053-23 Class 2, IEC 61557-12 Class 2
- Frequency:  $\pm 0.1\%$
- Current:  $\pm 0.2\%$
- Voltage:  $\pm 0.2\%$
- Power factor:  $\pm 0.01$
- Harmonic distortion: 2

### Wiring Diagram

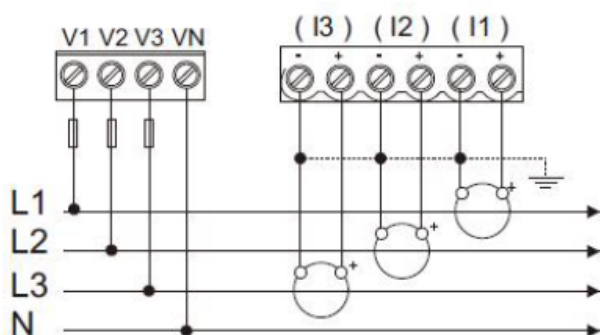

### Environment

- Operating temperature:  $-25^{\circ}\text{C}$  to  $+55^{\circ}\text{C}$
- Storage temperature:  $-40^{\circ}\text{C}$  to  $+70^{\circ}\text{C}$
- Humidity:  $< 95\%$  relative humidity at  $50^{\circ}\text{C}$  (non-condensing)
- Pollution degree: 2
- Altitude: Up to 3000 meters
- Vibration: 10Hz - 50Hz, according to IEC 60068-2-6 standard

### Digital Inputs

- Operating temperature:  $-25^{\circ}\text{C}$  to  $+55^{\circ}\text{C}$
- Count: 4
- Input resistance:  $10\ \Omega$
- Maximum frequency: 1 kHz
- Response time: 10 milliseconds
- Insulation: 2.5 kV AC for 1 minute

### Digital outputs

- Operating temperature:  $-25^{\circ}\text{C}$  to  $+55^{\circ}\text{C}$
- Count/Type: 2 - Electromagnetic relay
- Output frequency: Maximum 1 Hz
- Switching current: 3.0 Amper at 250 VAC (100,000 cycles)
- Insulation: 2.5 kV AC for 1 minute

### Dimensions

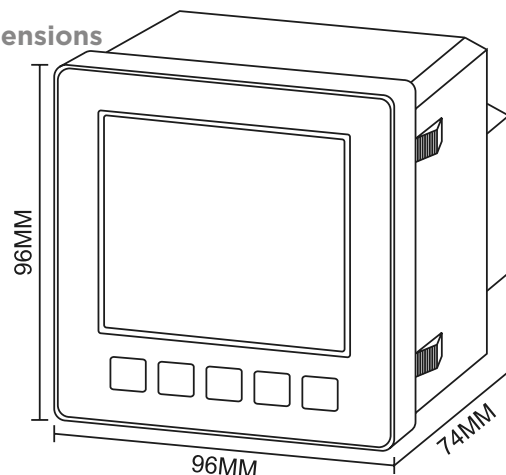

# aktif

ELEKTROTEKNİK

## Headquarters

Bayraktar Bul. Şehit Sok. No: 5  
34775 Ümraniye, İstanbul, TR  
Phone : +90 (216) 314 93 20  
Fax : +90 (216) 314 93 60  
www.aktif.net - info@aktif.net



## Factory

Akşemsettin Mah. Çatalca Sk. No: 113 06930  
Sincan, Ankara, TR  
Phone : +90 (312) 269 46 02  
Fax : +90 (312) 269 45 01  
www.aktif.net - info@aktif.net



## Germany Office

Bahnhofstrasse 82-86  
35390 Giessen, Germany  
Phone : +49 176 60940534  
www.aktif.net  
info.de@aktif.net

